



Contact Factory for more information.

Features

- Easy-to-set automatic *Expert*-style Static and Dynamic TEACH options, multiple Single-Point SET options, plus manual adjustment for fine tuning
- Smart power-control algorithm to maximize performance in low-contrast applications
- Normal mode provides 1.8 ms sensing response with improved crosstalk avoidance routine (for two sensors) and improved fluorescent light immunity
- Selectable high-speed (HS) mode option for 300-microsecond response (crosstalk avoidance and fluorescent light immunity disabled)
- Easy push-button Dark Operate/Light Operate select, output OFF-delay, and operating speed setup
- Powerful, highly collimated visible red sensing beam
- Tough ABS housing is rated IEC IP67; NEMA 6
- Easy-to-read operating status indicators, with 8-segment bargraph display
- Bipolar discrete outputs, PNP and NPN
- Selectable 30-millisecond OFF-delay
- Models available with 2 m or 9 m (6.5' or 30') cable or integral quick-disconnect
- Compact housing, mounting versatility – via popular 30 mm threaded barrel or side-mount

Models

Model	Range	Cable*	Supply Voltage	Output Type
QS30EDV	High-Speed Mode: 1,100 mm (43") Normal Mode: 1,400 mm (55")	2 m (6.5') 5-wire cable	10 to 30V dc	Bipolar NPN/PNP
QS30EDVQ		Integral 5-pin Euro-style QD		

* 9 m cables are available by adding suffix "W/30" to the model number of any cabled sensor (e.g., QS30EDV W/30).
A model with a QD connector requires a mating cable; see page 10.



WARNING . . . Not To Be Used for Personnel Protection

Never use these products as sensing devices for personnel protection. Doing so could lead to serious injury or death.

These sensors do NOT include the self-checking redundant circuitry necessary to allow their use in personnel safety applications. A sensor failure or malfunction can cause either an energized or de-energized sensor output condition. Consult your current Banner Safety Products catalog for safety products which meet OSHA, ANSI and IEC standards for personnel protection.

WORLD-BEAM® QS30EDV

Overview

The QS30EDV is an easy-to-use diffuse-mode sensor. It provides high-performance sensing in low-contrast applications. Its visible red beam provides easy sensor alignment. The sensor offers multiple configuration options, in addition to manual fine adjustment, remote programming, and security lockout options.

The sensor features bipolar outputs, one each NPN and PNP.

The sensor's compact housing has a large, easy-to-see bargraph display plus bright LEDs for easy configuration and status monitoring during operation. LEDs # 1–4 of the bargraph display also show configuration status during SETUP. The sensor can be side-mounted, using its integral mounting holes, or front-mounted, via its 30 mm threaded barrel.

Sensor Configuration

Sensor configuration is accomplished through TEACH or SET options, plus SETUP mode. After TEACH or SET have defined the sensing parameters, SETUP mode may be used to enable the delay, to change the Light Operate/Dark Operate status, or to select the high-speed response option (HS). Manual Adjust may be used to fine-tune the thresholds (see page 7). Two push buttons, Dynamic (+) and Static (-), or the remote wire, may be used to access and set the parameters.

Sensor configuration options include:

- Dynamic (on-the-fly) TEACH: a single switching threshold, determined by multiple sampled conditions
- Two-Point Static TEACH: a single switching threshold, determined by two taught conditions
- Window SET: a sensing window, centered on a single sensing condition
- Light SET and Dark SET: a single switching threshold, offset from a single sensing condition

Remote Configuration

The remote function may be used to configure the sensor remotely or to disable the push buttons for security. Connect the gray wire of the sensor to ground (0V dc), with a remote programming switch connected between them. Pulse the remote line according to the diagrams in the configuration procedures. The length of the individual programming pulses is equal to the value T:

$$0.04 \text{ seconds} \leq T \leq 0.8 \text{ seconds}$$

Returning to RUN Mode

Configuration modes each may be exited either after the 60-second time-out, or by exiting the process:

- In static TEACH or SET modes, press and hold the Static (-) button (or hold the remote line) for 2 seconds. The sensor returns to RUN mode without saving any new settings.
- In SETUP mode, press and hold both the Static (-) and Dynamic (+) buttons (or hold the remote line) for 2 seconds. The sensor returns to RUN mode and saves the current setting.

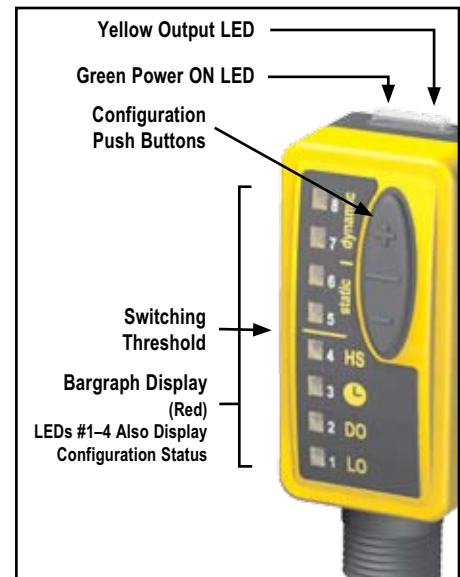

Figure 1. Features

Dynamic TEACH and Adaptive Thresholds

- Teach on-the-fly
- Sets a single switching threshold (switching point)
- Threshold position is adjustable using “+” and “-” buttons (Manual Adjust)
- Recommended for applications where a machine or process may not be stopped for teaching.

Dynamic TEACH is a variation of two-point TEACH. It programs the sensor during actual machine run conditions, taking multiple samples of the light and dark conditions and automatically setting the threshold at the optimum level (see Figure 2).

Dynamic TEACH activates the sensor’s adaptive threshold system, which continuously tracks minimum and maximum signal levels, and automatically maintains centering of the threshold between the light and dark conditions. The adaptive threshold system remains in effect during RUN mode. The adaptive routine saves to non-volatile memory at least once per hour.

When Dynamic TEACH mode is used, the output ON state (Light or Dark Operate) will remain as it was last programmed. To change the output ON state, use SETUP mode (see page 6).

The sensing threshold may be adjusted (fine-tuned) whenever the sensor is in RUN mode by clicking the “+” and “-” buttons. However, when a manual adjustment is made, the adaptive threshold system is disabled (cancelled).

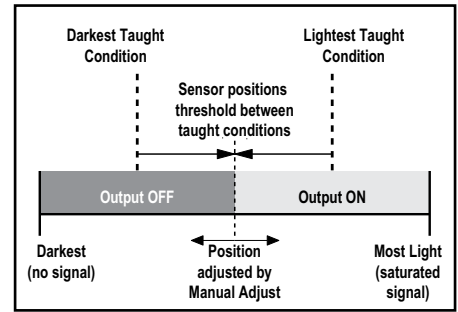
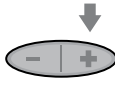
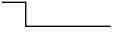
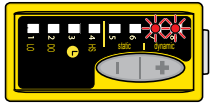
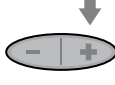
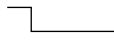
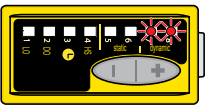
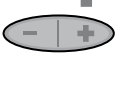
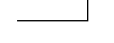
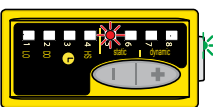



Figure 2. Two-Point Dynamic TEACH (Light Operate shown)

Bargraph LED*	Relative Signal Difference/ Recommendation
6 to 8	Excellent: Very stable operation.
4 to 5	Good: Minor variables will not affect sensing reliability.
2 to 3	Low: Minor sensing variables may affect sensing reliability.
1	Unreliable: Consider an alternate sensing scheme.

*Following TEACH

	Push Button	Remote Line	Result
Access Dynamic TEACH Mode	<ul style="list-style-type: none"> • Press and Hold Dynamic push button > 2 seconds 	<ul style="list-style-type: none"> • Hold remote line low (to ground) > 2 seconds 	Power LED: OFF Output LED: OFF Bargraph: #7 and 8 alternately flash 
TEACH Sensing Conditions	<ul style="list-style-type: none"> • Continue to hold push button • Present Output ON and OFF conditions 	<ul style="list-style-type: none"> • Continue to hold remote line low (to ground) • Present Output ON and OFF conditions 	Power LED: OFF Output LED: OFF Bargraph: #7 and 8 alternately flash 
Return to RUN Mode	<ul style="list-style-type: none"> • Release push button 	<ul style="list-style-type: none"> • Release remote line/switch 	Teach Accepted Power LED: ON Bargraph: One LED flashes to show relative contrast (good signal difference shown; see table above) Sensor returns to RUN mode with new settings 
			Teach Unacceptable Power LED: OFF Bargraph: #1, 3 and 5, 7 alternately flash to show failure Sensor returns to RUN mode without changing settings 

Two-Point Static TEACH (Threshold)

- Sets a single switching threshold (switching point)
- Threshold position is adjustable using “+” and “-” buttons (Manual Adjust).
- Recommended for applications where two conditions can be presented by the user.

Two-Point TEACH is the traditional configuration method. The sensor locates a single switchpoint at the optimal location between the two taught conditions, with the Output ON condition on one side, and the Output OFF condition on the other (see Figure 3).

The first condition taught is the ON condition. The Output ON and OFF conditions can be reversed by changing Light/Dark Operate status in SETUP mode (see page 6).

Two-Point TEACH and Manual Adjust

Using Manual Adjust with Two-Point TEACH moves the switching threshold position. The lighted LED on the bargraph will move to exhibit the received signal, relative to the threshold.

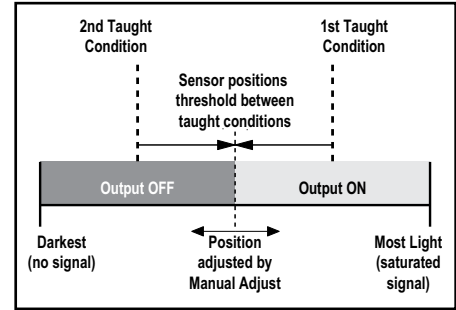

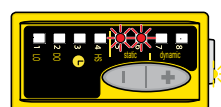
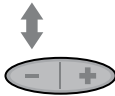

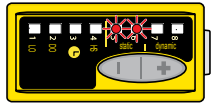
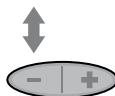

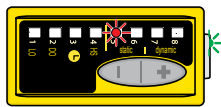
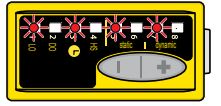

Figure 3. Two-Point TEACH (Light Operate shown)

Bargraph LED*	Relative Signal Difference/ Recommendation
6 to 8	Excellent: Very stable operation.
4 to 5	Good: Minor variables will not affect sensing reliability.
2 to 3	Low: Minor sensing variables may affect sensing reliability.
1	Unreliable: Consider an alternate sensing scheme.

*Following TEACH

	Push Button 0.04 seconds ≤ “Click” ≤ 0.8 seconds	Remote Line 0.04 seconds ≤ T ≤ 0.8 seconds	Result
Access TEACH Mode	<ul style="list-style-type: none"> • Press and hold Static button > 2 seconds 	<ul style="list-style-type: none"> • No action required; sensor is ready for 1st TEACH condition. 	<ul style="list-style-type: none"> • Power LED: OFF • Output LED: ON • Bargraph: #5 and 6 alternately flash 
Learn Output ON Condition	<ul style="list-style-type: none"> • Present Output ON condition • Click Static button 	<ul style="list-style-type: none"> • Present Output ON condition • Single-pulse remote line 	<ul style="list-style-type: none"> • Power LED: OFF • Output LED: Flash, then OFF • Bargraph: #5 and 6 alternately flash 
Learn Output OFF Condition	<ul style="list-style-type: none"> • Present Output OFF condition • Click Static button 	<ul style="list-style-type: none"> • Present Output OFF condition • Single-pulse remote line 	<ul style="list-style-type: none"> • Teach Accepted • Power LED: ON • Bargraph: One LED flashes to show relative contrast (good signal difference shown; see table above) • Sensor returns to RUN mode 
			<ul style="list-style-type: none"> • Teach Unacceptable • Power LED: OFF • Bargraph: #1, 3 and 5, 7 alternately flash to show failure • Sensor returns to “Learn Output ON Condition” 

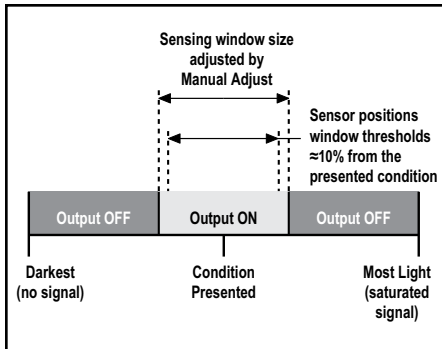

Figure 4. Single-Point Window SET (Light Operate shown)

Single-Point Window SET

- Sets a single ON condition that extends approximately 10% above and below the taught condition.
- All other conditions (lighter or darker) result in OFF output
- Sensing window size (sensitivity) is adjustable using the “+” and “-” buttons (Manual Adjust)
- Recommended for applications where the target to be sensed may not always appear in the same place, or when other signals may appear.

Single-Point SET designates a sensing window, by setting two switching thresholds at approximately 10% above and below the presented condition. The Output ON condition is inside the window, and the Output OFF conditions are outside the window (see Figure 4) when Light Operate is selected. Output ON and OFF conditions can be reversed by changing Light/Dark Operate status in SETUP mode.

Single-Point Window SET and Manual Adjust

Using Manual Adjust with Single-Point Window SET expands or contracts the size of the window. The lighted LEDs on the light bar separate to a greater or lesser extent to exhibit the relative sensing window size.

	Push Button 0.04 seconds ≤ “Click” ≤ 0.8 seconds	Remote Line 0.04 seconds ≤ T ≤ 0.8 seconds	Result
Access SET Mode	<ul style="list-style-type: none"> • Press and hold Static push button > 2 seconds 	<ul style="list-style-type: none"> • Present Output ON condition • Single-pulse remote line 	<ul style="list-style-type: none"> Power LED: OFF Output LED: ON (Push Button) Output LED: OFF (Remote) Bargraph: #5 and 6 alternately flash <p>Push Button</p> <p>Remote</p>
Set Output ON Condition	<ul style="list-style-type: none"> • Present Output ON condition • Double-click Static push button 	<ul style="list-style-type: none"> • Double-pulse remote line 	<p>Threshold Conditions Accepted</p> <ul style="list-style-type: none"> Power LED: ON Bargraph: 2 indicators flash together to show that the threshold conditions are accepted Sensor returns to RUN mode with new settings
			<p>Threshold Conditions Unacceptable</p> <ul style="list-style-type: none"> Power LED: OFF Bargraph: #1, 3 and 5, 7 alternately flash to show failure Sensor returns to “Access SET Mode”

Single-Point Light SET

- Sets a threshold approximately 10% below the taught condition.
- Any condition darker than the threshold condition causes the output to change state.
- Threshold position is adjustable using the “+” and “-” buttons (Manual Adjust).
- Recommended for applications where only one condition is known, for example a stable light background with varying darker targets.

A single sensing condition is presented, and the sensor positions a threshold approximately 10% below the presented condition. When a condition darker than the threshold is sensed, the output either turns ON or OFF, depending on the Light/Dark Operate setting (see SETUP mode, page 8).

Light SET and Light/Dark Operate Selection

In Light Operate mode, Light SET teaches the Output ON condition. In Dark Operate mode, Light SET teaches the Output OFF condition.

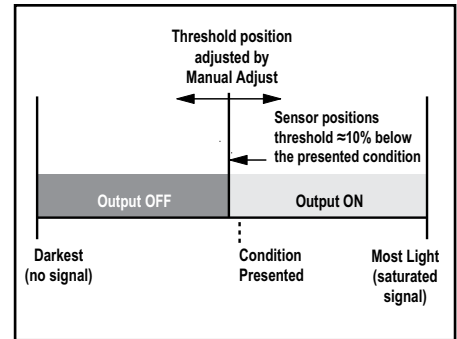
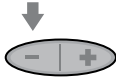

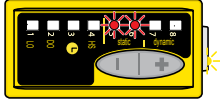
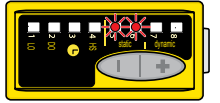
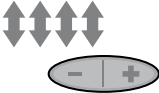
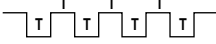
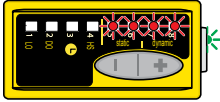
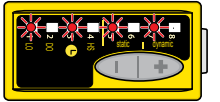

Figure 5. Single-Point Light SET (Light Operate shown)

	Push Button $0.04 \text{ seconds} \leq \text{“Click”} \leq 0.8 \text{ seconds}$	Remote Line $0.04 \text{ seconds} \leq T \leq 0.8 \text{ seconds}$	Result
Access SET Mode	<ul style="list-style-type: none"> • Press and hold Static push button > 2 seconds 	<ul style="list-style-type: none"> • Present Output ON condition • Single-pulse remote line 	<p>Power LED: OFF Output LED: ON (Push Button) Output LED: OFF (Remote) Bargraph: #5 and 6 alternately flash</p> <p>Push Button</p>  <p>Remote</p> 
Set Output ON Condition	<ul style="list-style-type: none"> • Present Output ON condition • Four-click Static push button 	<ul style="list-style-type: none"> • Four-pulse remote line 	<p>Threshold Condition Accepted Power LED: ON Bargraph: Indicators #5–8 flash together to show that the threshold condition is accepted Sensor returns to RUN mode with new settings</p> 
			<p>Threshold Condition Unacceptable Power LED: OFF Bargraph: #1, 3 and 5, 7 alternately flash to show failure Sensor returns to “Access SET Mode”</p> 

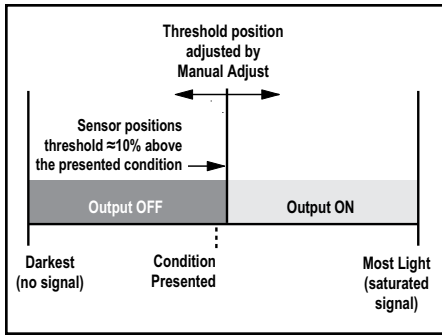

Figure 6. Single-Point Dark SET (Light Operate shown)

Single-Point Dark SET

- Sets a threshold approximately 10% above the taught condition.
- Any condition lighter than the threshold condition causes the output to change state.
- Threshold position is adjustable using the “+” and “-” buttons (Manual Adjust).
- Recommended for applications where only one condition is known, for example a stable dark background with varying lighter targets.

A single sensing condition is presented, and the sensor positions a threshold approximately 10% above the taught condition. When a condition lighter than the threshold is sensed, the output either turns ON or OFF, depending on the Light/Dark Operate setting (see SETUP mode, page 8).

Dark SET and Light/Dark Operate Selection

In Light Operate mode, Dark SET teaches the Output OFF condition. In Dark Operate mode, Dark SET teaches the Output ON condition.

	Push Button 0.04 seconds ≤ “Click” ≤ 0.8 seconds	Remote Line 0.04 seconds ≤ T ≤ 0.8 seconds	Result
Access SET Mode	<ul style="list-style-type: none"> • Press and hold Static push button > 2 seconds 	<ul style="list-style-type: none"> • Present Output ON condition • Single-pulse remote line 	Power LED: OFF Output LED: ON (Push Button) Output LED: OFF (Remote) Bargraph: #5 and 6 alternately flash
SET Output ON Condition	<ul style="list-style-type: none"> • Present Output ON condition • Five-click Static push button 	<ul style="list-style-type: none"> • Five-pulse remote line 	Threshold Condition Accepted Power LED: ON Bargraph: Indicators #1–4 flash together to show that the threshold condition is accepted Sensor returns to RUN mode with new settings
			Threshold Condition Unacceptable Power LED: OFF Bargraph: #1, 3 and 5, 7 alternately flash to show failure Sensor returns to “Access SET Mode”

WORLD-BEAM® QS30EDV

SETUP Mode

SETUP mode is used to change sensor output response for:

- Light or Dark operate
- 30-millisecond pulse stretcher (OFF delay), if required.
- 300 μ s high-speed response

If SETUP mode programming is interrupted and remains inactive for 60 seconds, the sensor returns to RUN mode with the most recent settings (i.e., exits and saves current selection).

SETUP mode operates in the “background”, while the outputs are active; changes are updated instantly.

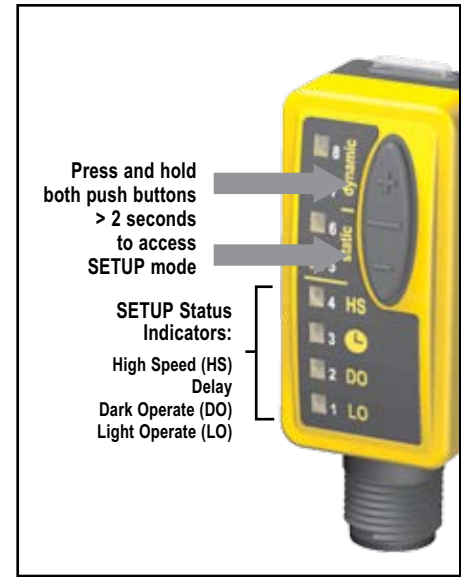

Figure 7. SETUP mode

	Push Button 0.04 seconds \leq "Click" \leq 0.8 seconds	Remote Line 0.04 seconds \leq T \leq 0.8 seconds	Result
Access SETUP Mode	<ul style="list-style-type: none"> • Press and hold both push buttons > 2 seconds 	<ul style="list-style-type: none"> • Double-pulse remote line 	<ul style="list-style-type: none"> • Green Power LED turns OFF • Output LED remains active • Status indicators (bargraph #1–4) flash current setup
Select Setting Combination	<ul style="list-style-type: none"> • Click either push button until LEDs show desired settings 	<ul style="list-style-type: none"> • Pulse the remote line until LEDs show desired settings <p>NOTE: Double-pulsing the remote line will cause the setting to “back up” one step.</p>	<p>Sensor rotates through eight setting combinations, in the following order:</p> <ul style="list-style-type: none"> Normal Speed - No Delay - LO* Normal Speed - No Delay - DO Normal Speed - Delay - LO Normal Speed - Delay - DO High Speed - No Delay - LO High Speed - No Delay - DO High Speed - Delay - LO High Speed - Delay - DO <p>*Factory Default setting</p>
Return to RUN Mode	<ul style="list-style-type: none"> • Press and hold both push buttons > 2 seconds 	<ul style="list-style-type: none"> • Hold remote line low > 2 seconds 	<ul style="list-style-type: none"> • Green Power LED turns ON • Sensor returns to RUN mode with new settings

Manual Adjust

Manual Adjust is used during RUN mode and is accomplished via the push buttons only. Its behavior depends on whether a switching threshold or a sensing window is used.

Switching Threshold:

- Fine-tunes sensing sensitivity
- Press “+” to increase; press “-” to decrease

Sensing Window:

- Adjusts sensing window size (tolerance) for the single-point target condition
- Press “+” to increase; press “-” to decrease

The lighted bargraph LEDs move to reflect the increase or decrease.

Push Button Disable

In addition to its programming function, Remote Programming may be used to disable the push buttons for security. Disabling the push buttons prevents undesired tampering with the programming settings. Connect the gray wire of the sensor as described on page 2, and four-pulse to either enable or disable the push buttons:

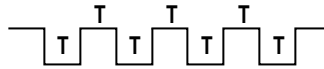

Bar Graph Indicator Functions

RUN Mode

The lighted bargraph segment represents relative distance from the cutoff point. Its behavior depends on whether a sensing window or a sensing threshold is taught. See Figure 8.

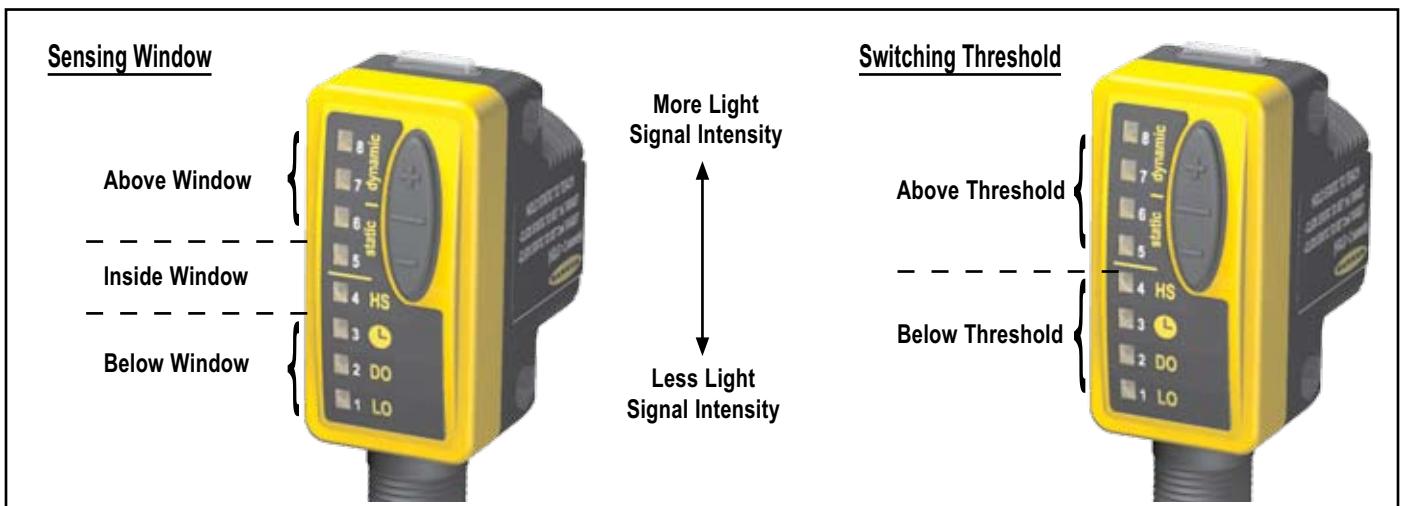



Figure 8. Bargraph indications in RUN mode for Sensing Window and Sensing Threshold applications

WORLD-BEAM® QS30EDV

Specifications

Sensing Beam	660 nm visible red
Supply Voltage	10 to 30V dc (10% max. ripple) @ 25 mA max current, exclusive of load
Supply Protection Circuitry	Protected against reverse polarity, over voltage, and transient voltages
Delay at Power-Up	250 ms; outputs do not conduct during this time
Output Configuration	Bipolar: 1 current sourcing (PNP) and 1 current sinking (NPN)
Output Ratings	150 mA maximum load (derate ~ 1 mA/°C above 25°C) OFF-state leakage current: < 50 µA at 30V dc ON-state saturation voltage: NPN: < 200 mV @ 10 mA; < 1V @ 150 mA PNP: < 1.25V @ 10 mA; < 2V @ 150 mA
Output Protection	Protected against output short-circuit, continuous overload, transient over-voltages, and false pulse on power up
Output Response Time	High-Speed Mode: 300 microseconds Normal Mode: 1.8 ms
Repeatability	High-Speed Mode: 100 microseconds Normal Mode: 150 microseconds
Adjustments	2 push buttons and remote wire <ul style="list-style-type: none"> • Easy push-button configuration • Manually adjust (+/-) cutoff (push buttons only) • Light Operate/Dark Operate and OFF-delay configuration options (push buttons only) • Push-button lockout (from remote wire only)
Indicators	8-segment red bargraph: Distance relative to cutoff point Green LED: Power ON Yellow LED: Output conducting
Construction	ABS plastic housing; acrylic lens cover
Environmental Rating	IP67, NEMA 6
Connections	5-conductor 2 m (6.5') PVC cable, 9 m (30') PVC cable, or 5-pin integral Euro-style quick-disconnect fitting
Operating Conditions	Temperature: -10° to +55°C (+14° to 122°F), Max. relative humidity: 90% @ 55°C (non-condensing)
Vibration and Mechanical Shock	All models meet Mil. Std. 202F requirements. Method 201A (Vibration: 10 to 60 Hz max. double amplitude 0.06", maximum acceleration 10G). Also meets IEC 947-5-2 requirements: 30G, 11 ms duration, half sine wave.
Certifications	

Performance Curves

Performance based on use of 90% reflectance white test card

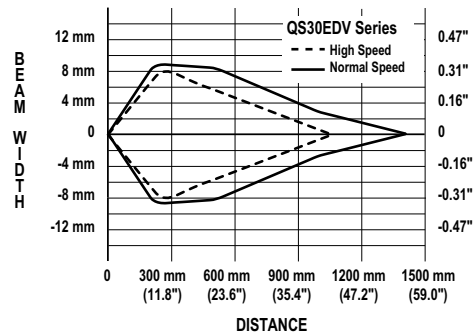
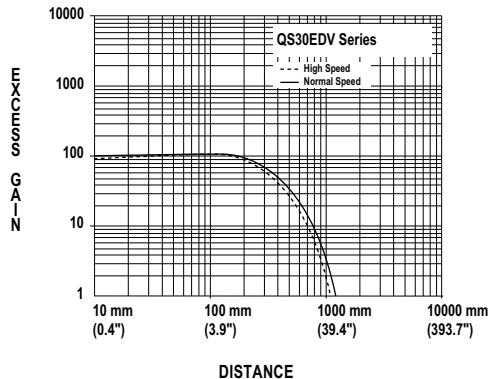

Dimensions

Cabled Models

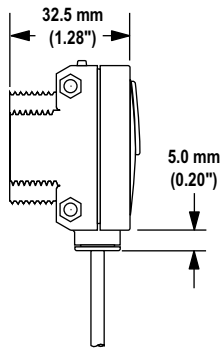

Hardware Included:

(10) M3 x 0.5 x 28 stainless steel machine screws, nuts and washers

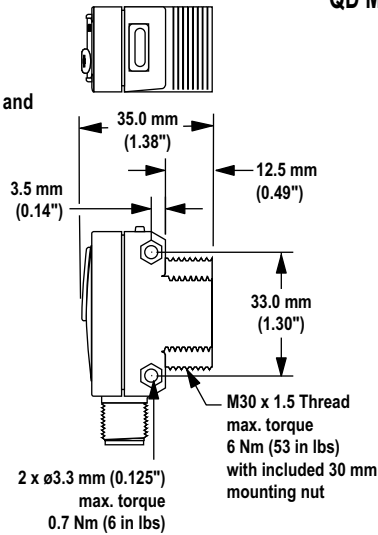
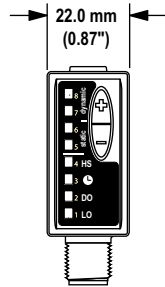

QD Models

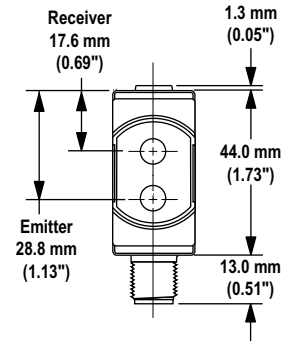

Hookups

Cabled Models

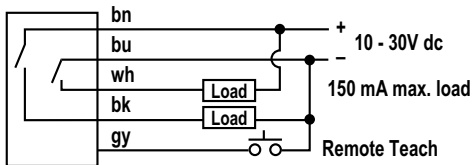

QD Models

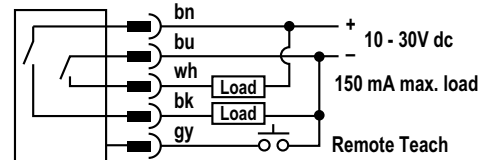

Accessories

Quick-Disconnect Cables

Style	Model	Length	Dimensions	Pinout
5-pin Euro-style straight	MQDC1-506 MQDC1-515 MQDC1-530	2 m (6.5') 5 m (15') 9 m (30')		
5-pin Euro-style right-angle	MQDC1-506RA MQDC1-515RA MQDC1-530RA	2 m (6.5') 5 m (15') 9 m (30')		

WORLD-BEAM® QS30EDV

Brackets

<p>SMBQS30L</p>	<ul style="list-style-type: none"> • 14-gauge, stainless steel right-angle bracket for cable models • Clearance for M4 (#8) hardware • $\pm 12^\circ$ tilt adjustment 	<p>SMBQS30LT</p>	<ul style="list-style-type: none"> • 14-gauge stainless steel for QD models with right-angle cables • Tall right-angle mounting bracket • $\pm 8^\circ$ tilt adjustment
<p>SMBQS30Y</p>	<ul style="list-style-type: none"> • Heavy-duty die-cast bracket • M18 vertical mounting option • $\pm 8^\circ$ tilt adjustment with cabled units • Nuts and lockwasher included 	<p>SMBQS30YL</p>	<ul style="list-style-type: none"> • Heavy-duty die-cast bracket designed for industrial protection • Replaceable window • M18 vertical mount option • Includes nuts and lock washer
<p>Other Compatible Mounting Brackets:</p> <ul style="list-style-type: none"> • SMB30MM • SMB30SC • SMB30A 			



WARRANTY: Banner Engineering Corp. warrants its products to be free from defects for one year. Banner Engineering Corp. will repair or replace, free of charge, any product of its manufacture found to be defective at the time it is returned to the factory during the warranty period. This warranty does not cover damage or liability for the improper application of Banner products. This warranty is in lieu of any other warranty either expressed or implied.